



MMI RAPID CONNECT

Portable Starlink Deployment System



ewan@mcintyremarine.com



+44 7545 331 889



www.mcintyremarine.com



MMI PRODUCTS

Engineered for Professional Yacht Operations

What is Rapid Connect

Rapid Connect™ is a portable Starlink Mini deployment system designed to provide fast, reliable connectivity wherever fixed infrastructure is unavailable.

Supplied in a Peli Products UK Storm case to provide premium protection for the Starlink Mini during transport, storage and deployment.

Operational Use	Guest & Support Use
Remote anchorage and off-grid connectivity	Charter and guest experience support
Tender and shoreside deployment	Beach club and remote guest setups
Backup communications during system outages	Discreet redundancy for high-value guest operations
Engineering diagnostics and remote access	Temporary off-vessel work zones



Developed in partnership with Peli Products UK.





Rapid Connect Platform

Rapid Connect™ is designed as a flexible connectivity platform rather than a fixed-format product. The system adapts to different deployment requirements, allowing it to scale across multiple use cases while maintaining a consistent product identity.

RC-01	RC-02	RC-HFM
Peli Products UK Storm iM2300	Peli Products UK Storm iM2400 SKU: iM2400-02000	Peli Products UK Protector 1560 SKU: 1560-001-110
<ul style="list-style-type: none">• Lightweight• Rapid deployment• Minimal footprint	<ul style="list-style-type: none">• Increased capacity• Internal charger option• Balanced deployment + runtime	<ul style="list-style-type: none">• Wheeled transport• Larger battery capacity• Extended deployment capability

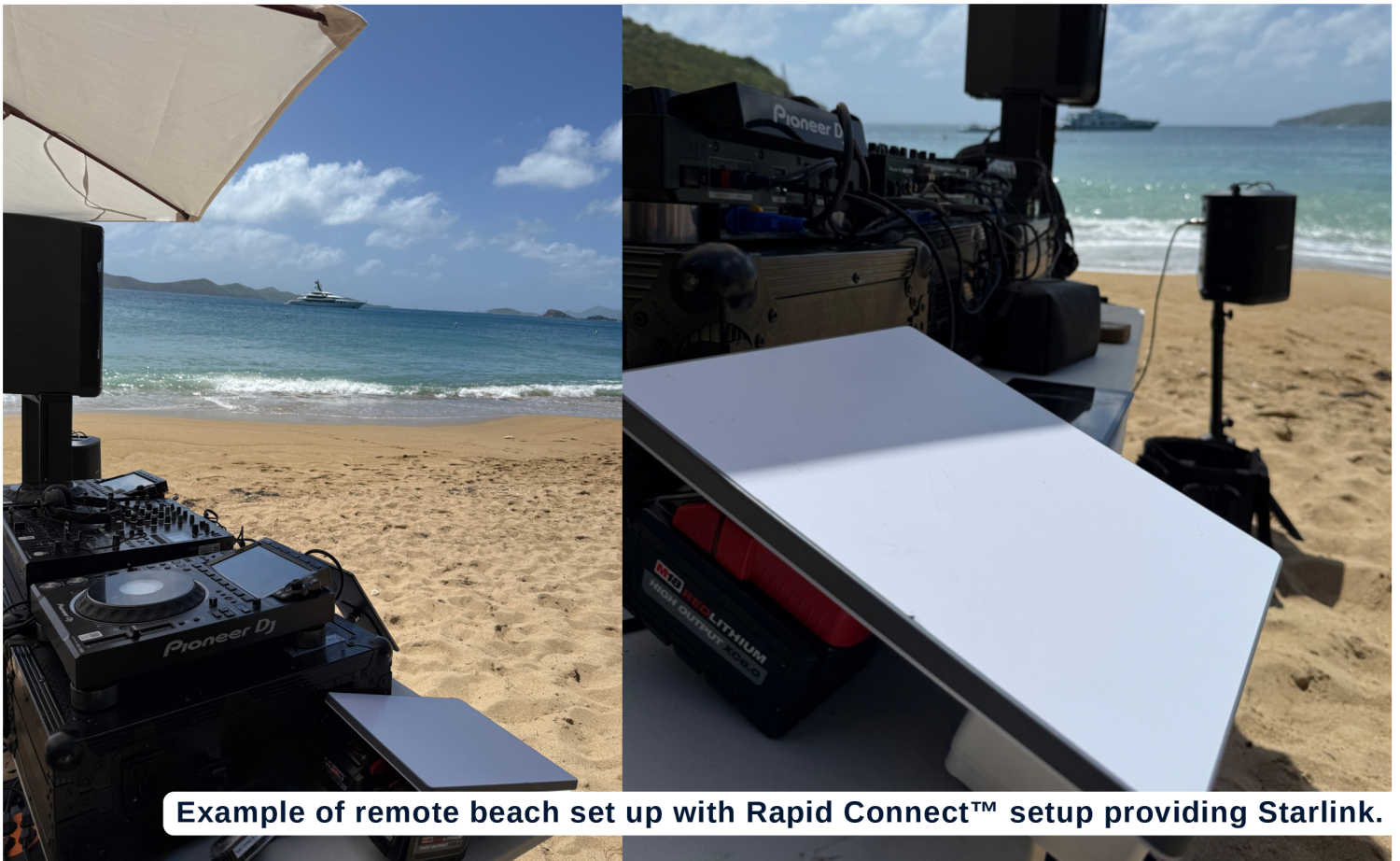

Example of remote beach set up with Rapid Connect™ setup providing Starlink.



Storm Case (RC-01 / RC-02)

RC-01: Our most compact Rapid Connect configuration, designed for the smallest possible transport footprint while still delivering a fully operational deployment setup. This option accommodates the unit with two batteries fitted. Plus two additional spare batteries, stowed and pre-charged, giving users a lightweight, highly portable system with immediate backup power available.

RC-02: A compact but enhanced mid-size deployment option that maintains a small overall footprint while providing additional operational flexibility. This version includes space for a single battery charging unit with 12V vehicle charging capability, making it ideal for guest operations away from the vessel. The system can run on one battery when required, while spare charged batteries can be rotated into use as the other two are charged in turn, supporting longer off-vessel deployment with practical charging support.

Construction Features

- Lightweight HPX resin
- IP67 rated protection
- Press & pull latches
- Rubber O-ring seal
- Vortex® pressure valve
- Rubber overmoulded handles
- Padlock hasps

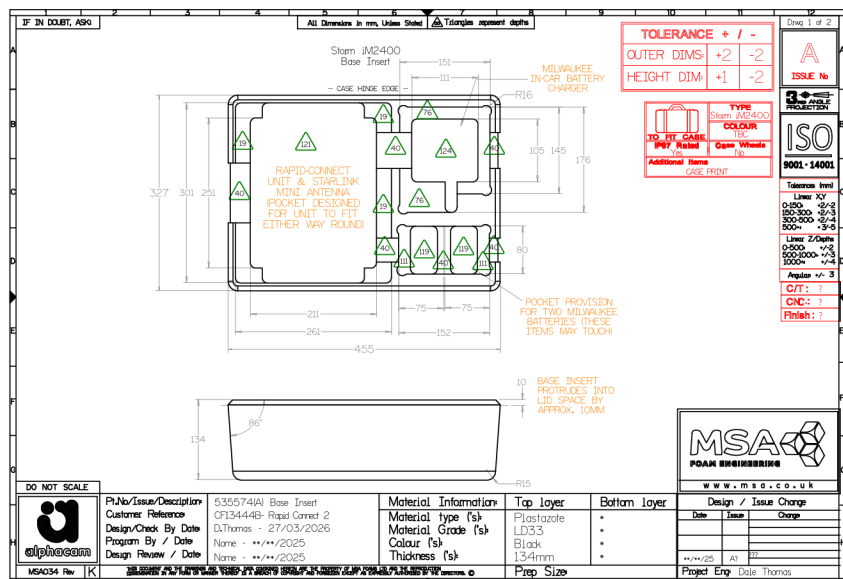
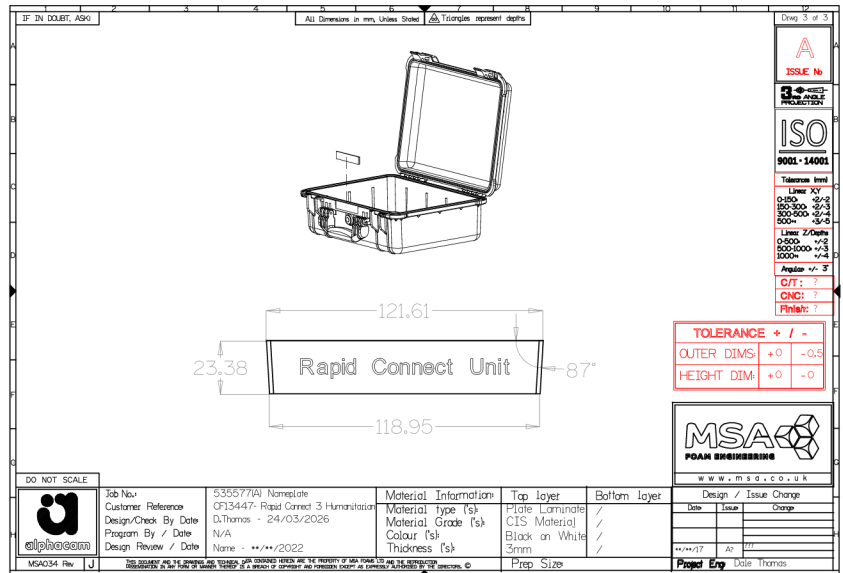

CONTACT



MCINTYRE MARINE INSPECTIONS

Distributor, trade and collaboration enquiries welcome



McIntyre Marine Inspections Ltd



ewan@mcintyremarine.com



+44 7545 331 889



www.mcintyremarine.com